



NO2 DUCT

Nitrogen Dioxide Duct Sensor

The NO2 Duct Series monitors nitrogen dioxide (NO2) levels and is designed for the continuous monitoring of vehicle exhaust in non-hazardous areas. This series uses a wide spectrum electrochemical sensor to measure the amount of nitrogen dioxide in the environment. It is offered with an operating range of 0 to 6 ppm. The Duct NO2 transmitter is offered in a standard NEMA 1 rated ABS Polycarbonate plastic enclosure. Other options include an LCD display with (2) SPDT Form 1C relays and a buzzer. Refer to all applicable Federal, State, Provincial and Local Health and Safety laws and regulations before using these products. NO2-D is not compatible with the Q4C-II or Q-Controllers.

Applications: Parking Garages, Arenas, Warehouses, Loading Docks, Service Garages, School Bus Parking Areas

The NO2 Duct Series Gas Transmitters are covered by ACI's Two (2) Year Limited Warranty against defects in material and workmanship from the date of shipment with the exception of the Sensor Modules (Electrochemical/Toxic: Six Months and Catalytic/Combustible: One Year). The warranty can be found in the front of ACI's Sensors & Transmitters catalog, as well as on ACI's website, workaci.com.

PRODUCT SPECIFICATIONS

Supply Voltage:	24 VAC +/- 10% Floating; 24 VAC +/- 10%, One side Grounded; 24 VDC
Supply Current:	100 mA nominal 250 mA maximum
Power Usage:	6.6 Watts maximum
Operating Temperature:	-4°F to 104°F (-20°C to 40°C)
Operating Humidity:	15 to 90% RH Continuous, non-condensing; 0 to 99% RH Intermittent, non-condensing
Accuracy:	+/- 2.5% of Reading
Repeatability:	+/- 1% of Reading
Operating Pressure:	Atmospheric +/- 10%
Response Time:	Less than 60 Seconds for 90% of step change
Sensor Type:	Electrochemical
Sensor Life:	2-3 years under Normal Conditions
Factory Set Range:	0 to 6 ppm 0 to 10 ppm Field Adjustable
Indicators:	Alphanumeric, 2 line X 8 digit LCD / (2) Red LED's for Relay Status
Analog Outputs:	4-20 mA or 2-10V Jumper Selectable
Relay & Buzzer (Optional):	Two SPDT Form C, Dry Contact, 1A @ 30 VDC/0.5A @ 125 VAC (Resistive Load), Buzzer Rating 85 dB @ one foot
Relay Life Expectancy:	200,000 cycles minimum with 1A @ 30VDC
Time Delays:	Actuation / De-Actuation: 0 to 60 Minutes in 5 minute Increments
Storage:	32°F to 68°F
Unit Shelf Life:	6 months from date of purchase
Duct Kit Tubing Material:	Vinyl
Duct Kit Tubing Length:	18"
Duct Kit In-Line Filter:	5 micron
Duct Kit Pitot Tube:	3 5/32", Polycarbonate/ABS Blend / UL94V
Enclosure:	Polycarbonate/ABS Blend, Fire Retardant
Terminal Blocks:	Power wiring: 16 to 26 AWG (0.2 to 1.00 mm ²) Shielded Twisted Pair
Terminal Block Torque Rating:	0.37 ft-lbs (0.5n-3m) Nominal
Communication Wiring:	Beldon 9841 or equal
Equipment Needed For Calibration:	0.5 lpm Regulator, zero & span gas (supplied by local vendor) Calibration adapter (Part # 83830-020-000)
Replacement NO2 Sensor:	Part# 6300-0035
Product Dimensions:	(H) 6.00" (152.4 mm) x (W) 3.5" (88.9 mm) x (D) 1.6" (40.6 mm)
Product Weights:	1.00 lbs (0.45 kg)

Note: Sensors and system should be scheduled to be tested for accuracy and functionality every 6 months for toxic, and every 3 months for combustible | Recalibrate or replace sensor boards if necessary | When installed @ > 3000' above sea level, the gas transmitters must be verified for accuracy & re-calibrated as needed after installation



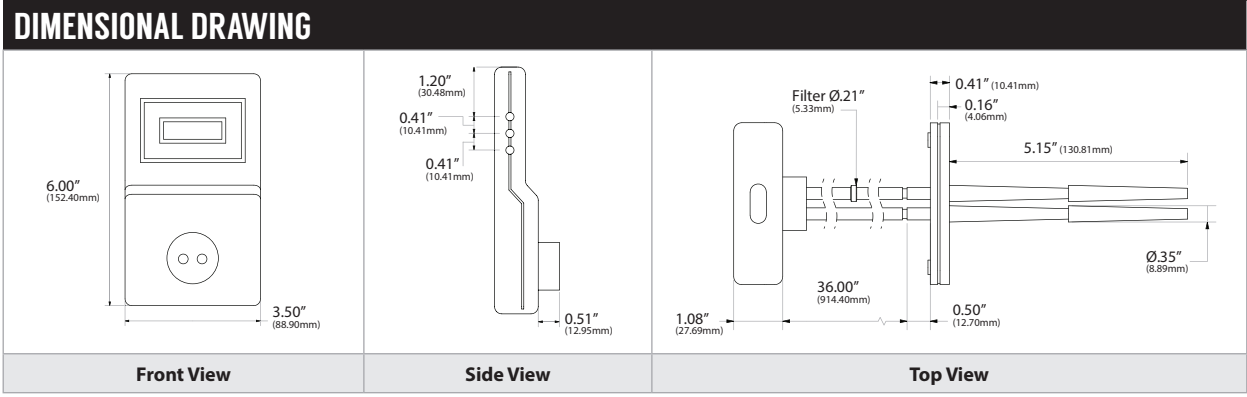

STANDARD ORDERING

Model # Example: **NO2-D-RB-D** -OR- **113012**

Model #	Item #	Description
NO2-D	109680	NO2 Duct Mount, Standard Enclosure
NO2-D-RB-D	113012	NO2 Duct Mount with Display, Relays (2x SPDT), Buzzer, Standard Enclosure

ACCESSORIES ORDERING

Model # Example: **83830-020-000** -OR- **127649**

Model #	Item #	Description
83830-020-000	127649	Calibration Adapter
6300-0035	128873	Repacement NO2 Sensing Element
CUSTOM CAL KIT*	148426	Gas Cal Kit

Note*: Refer to GAS CAL KIT data sheet for specific's

